

# Real-Life Math

**FRACTIONS, RATIOS,  
AND RATES**

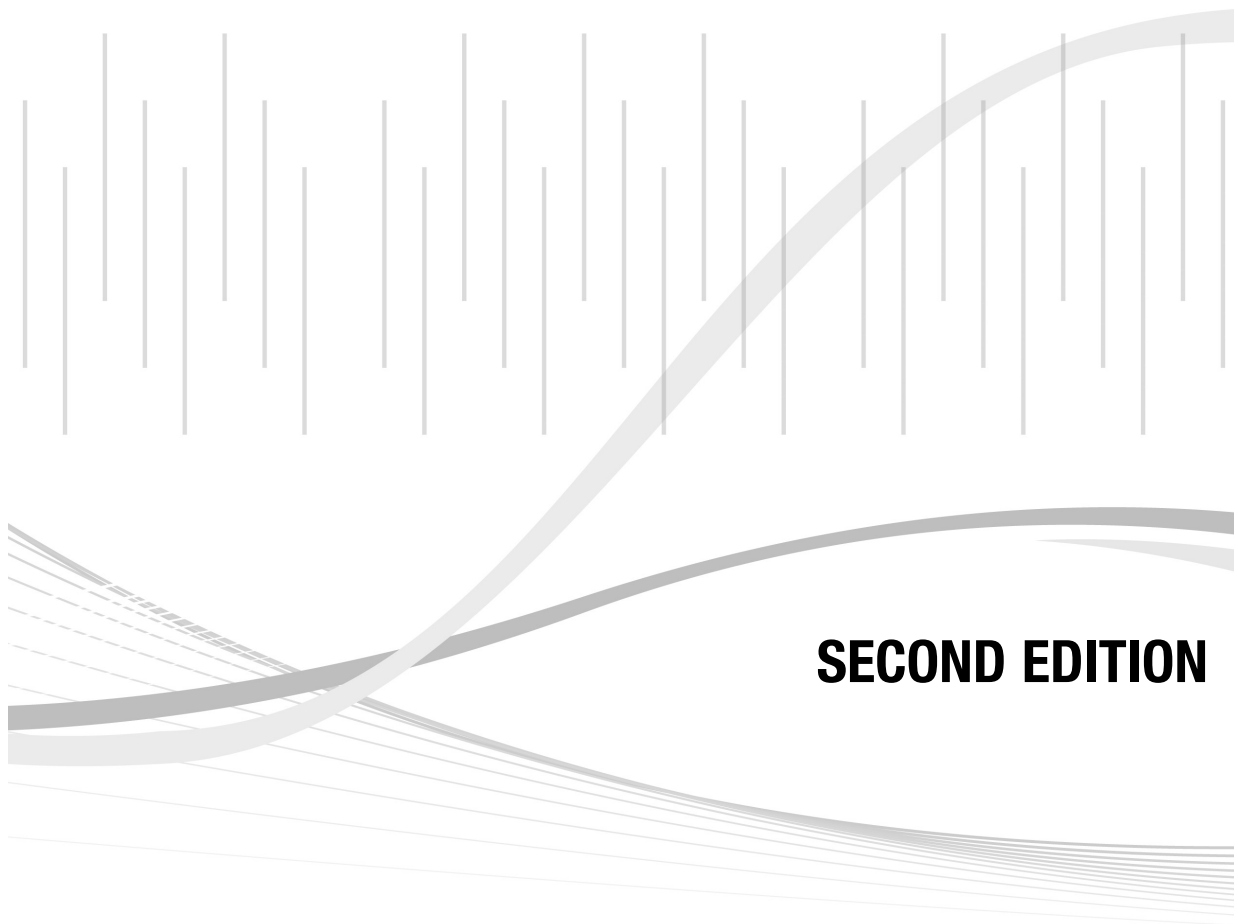

**SECOND EDITION**

**WALCH**  **PUBLISHING**

# Table of Contents

---

*How to Use This Series* . . . . . *v*

*Foreword* . . . . . *vi*

## **Fractions**

1. A Construction Site . . . . .	1
2. Selling Carpet . . . . .	4
3. Sports Standings . . . . .	8
4. Cooking More Chili . . . . .	14
5. Baking Fewer Cookies . . . . .	17

## **Rates with Conversions**

6. Miles Per Hour . . . . .	19
7. Miles Per Gallon . . . . .	23
8. Stock-Car Fuel Strategy . . . . .	26
9. Earned Run Average . . . . .	29
10. Currency Trading . . . . .	32

## **Rates with Formulas**

11. Heating Degree Days . . . . .	35
12. Batting Average . . . . .	37
13. Slugging Average . . . . .	40
14. Exercise and Calories . . . . .	43

## **Rates with Money**

15. Tipping . . . . .	45
16. Produce, Meats, and Cheeses . . . . .	47
17. Unit Pricing . . . . .	49
18. Rate of Pay . . . . .	52

# Table of Contents

---

## Rates with Exponents

19.	Population Growth Rates	56
20.	Half-Life	59
21.	Mortgage Rates	62
22.	Auto Loan Rates	64

## Ratios

23.	A Trip to Canada	67
24.	Hat Sizes	70
25.	The Musical Scale	72
26.	The Respiratory Quotient	75
27.	Delivering Heating Oil	78
28.	Packaging and Product Size	81
29.	Price-Earnings Ratio	84

## How to Use This Series

---

The *Real-Life Math* series is a collection of activities designed to put math into the context of real-world settings. This series contains math appropriate for pre-algebra students all the way up to pre-calculus students. Problems can be used as reminders of old skills in new contexts, as an opportunity to show how a particular skill is used, or as an enrichment activity for stronger students. Because this is a collection of reproducible activities, you may make as many copies of each activity as you wish.

Please be aware that this collection does not and cannot replace teacher supervision. Although formulas are often given on the student page, this does not replace teacher instruction on the subjects to be covered. Teaching notes include extension suggestions, some of which may involve the use of outside experts. If it is not possible to get these presenters to come to your classroom, it may be desirable to have individual students contact them.

We have found a significant number of real-world settings for this collection, but it is not a complete list. Let your imagination go, and use your own experience or the experience of your students to create similar opportunities for contextual study.

## Foreword

---

As a mathematician, I have to admit that I always used to greet the question, “When are we ever going to use this?” with some annoyance. It was obvious to me that students needed the material to do well on my tests and maybe in future classes. Admittedly, that doesn’t give students, unless they really just love math, much on which to hang their hats. With greater experience, I began answering the question with esoteric phrases about how well math trains one’s mind and why training the mind is the highest goal of a good education. Still, some students stare at me blankly, trying to find the “real” meaning of their math voyage.

Well, we really DO use math every day. Yes, sometimes it is just to balance a checkbook or to make change, but in an incredible variety of professional and personal settings, we use math skills that were drilled into us without the slightest hint of a context. Once I started to think about all the areas of life where math and mathematical thought were central, I started having fun. I have talked with stockbrokers, restaurateurs, mechanics, haberdashers, contractors, baseball statisticians, bankers, carpet salespeople, and grocers to learn about how they use math each day. I hope that these activities will be as much fun for your students and provide them with as much contextual background as they have for me. As a teacher, you will be amazed by how open professionals in other fields are to helping your students extend their understanding and grounding in learning math.

—Tom Campbell

# 1. A Construction Site

---

Rulers and measuring tapes are often divided into inches. Inches are sometimes broken into halves, quarters, eighths, tenths, or sixteenths depending on the measurer. The inches can also be grouped in sets of 12 into feet. Most measurements in the construction business are given in feet, inches, and fractions of inches.

Brian McDonald has a general contracting business. He and his employees always measure carefully to make sure they cut their materials correctly. On a recent job site, they encountered the following situations. Give Brian's crew a hand with their measurements by answering the questions below.

1. Brian is putting in a countertop. He is going to put the countertop flush against the wall on one end and trim it with a board that is  $\frac{9}{16}$  inch thick on the other end. If Brian wants the counter to end exactly 9 feet,  $6\frac{1}{2}$  inches from the wall, how long should he cut the countertop?
  
2. Brian has hired Matteen to build the deck. Matteen can just fit a deck that is 13 feet, 6 inches along the side of the house by 10 feet 4 inches out from the house. The customer wants a railing; however, that will be  $3\frac{1}{2}$  inches wide, running around the three sides not attached to the house. What will be the dimensions of the "livable space" on the deck?
  
3. Brian has hired Sarah to build a square window frame out of wood that is  $\frac{3}{4}$  inch thick. The dimensions need to be 4 feet,  $3\frac{1}{4}$  inches square. If Sarah cuts the two sides of the square to be 4 feet,  $3\frac{1}{4}$  inches long, how long should she cut the top and bottom pieces to fit between these two sides?

*(continued)*

## 1. A Construction Site

---

4. Lori has been hired to build the frame and outer walls of the house. The exterior walls will be made of  $\frac{3}{8}$ -inch drywall,  $3\frac{1}{2}$ -inch-wide studs,  $\frac{1}{4}$ -inch-thick exterior plywood, and  $\frac{5}{16}$ -inch-thick siding. How thick are the new walls altogether?
  
5. Rayhan has been hired to build a rectangular box out of  $\frac{3}{8}$ -inch-thick wood as a curio shelf. He wants the box to be 6 inches long and  $4\frac{1}{4}$  inches wide. If he insets the bottom into the box, to what dimensions should he cut the piece for the bottom?
  
6. The house is 26 feet,  $4\frac{3}{4}$  inches wide on the outside. Brian wants to cut his clapboards to fit the sides, but he knows that the corner trim covers  $3\frac{1}{8}$  inches in from the edge on each end. How long should he cut the clapboards?
  
7. Concrete will be poured into forms at the job site tomorrow. The wall to be poured is to be 15 feet,  $5\frac{3}{8}$  inches long. Rayhan and Brian already have a form that is 12 feet, 6 inches long. How long should they make an additional form to make the wall the right length?
  
8. Brian has asked Matteen to build a doorway for an existing door. Matteen knows that the door is  $41\frac{3}{4}$  inches wide and  $90\frac{3}{8}$  inches tall. He knows the jamb will be  $4\frac{3}{4}$  inches thick on the top and two sides of the doorway. What are the dimensions of the hole he should create in the wall to accommodate the doorjamb and the door?

## 2. Selling Carpet

Kevin's Carpet World has been installing office carpeting for years. They are now trying to break into the home carpeting business. When customers come into the salesroom, Kevin asks them to bring an accurate floor plan of the room(s) to be carpeted. The staff can then calculate the square yardage of the floor to determine the price of the carpeting. Kevin's prices include a 6-pound pad and installation, so customers have only one price to consider.

For each situation below, help Kevin determine the price of the carpet installation.

- The Winston family is installing a playroom in their basement. They like the Berber carpet that is on sale for \$12.99 a square yard. What price should be charged assuming the following floor plan is accurate?

Total cost: \_\_\_\_\_

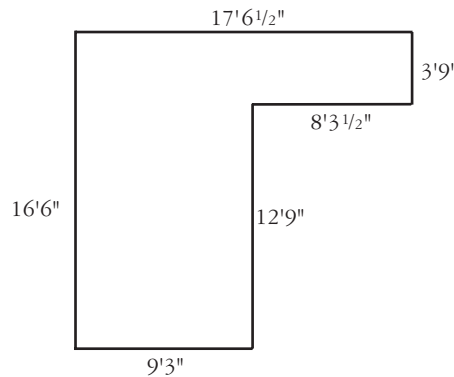

- The Khin family is carpeting their living room. They have chosen a deep-pile carpet that sells for \$24.95 a square yard. How much should they be charged based on the following floor plan?

Total cost: \_\_\_\_\_

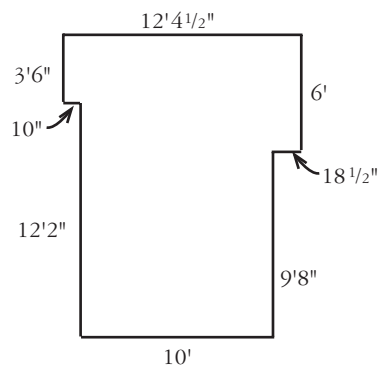

*(continued)*

## 2. Selling Carpet

3. The Trafton family wants to install outdoor carpeting around their in-ground pool. The outdoor carpeting they have selected is \$8.99 a square yard. How much should they be charged based on the following plan of the pool area?

Total cost: \_\_\_\_\_

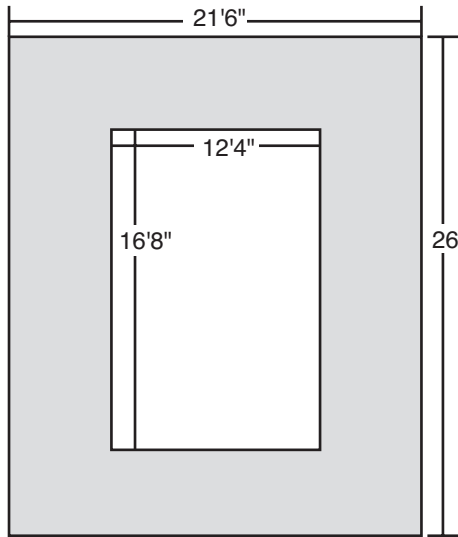

4. The Cowen family is carpeting their dining room. They have chosen a low-pile carpet that sells for \$18.75 a square yard. How much should they be charged based on the following floor plan?

Total cost: \_\_\_\_\_

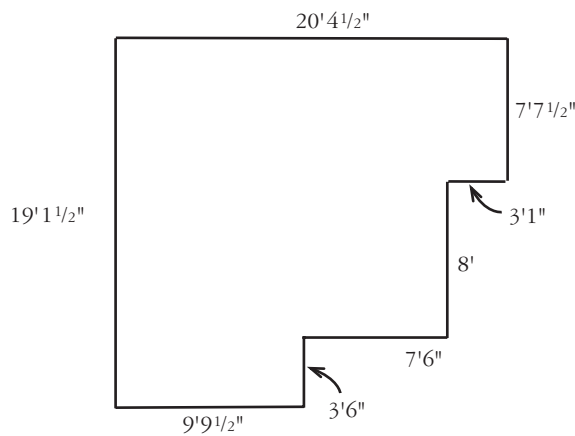

*(continued)*

## 2. Selling Carpet

5. The Taylor family is carpeting their bedrooms. They have chosen a soft carpet that sells for \$18.15 a square yard. How much should they be charged based on the following floor plans?

Total cost: \_\_\_\_\_

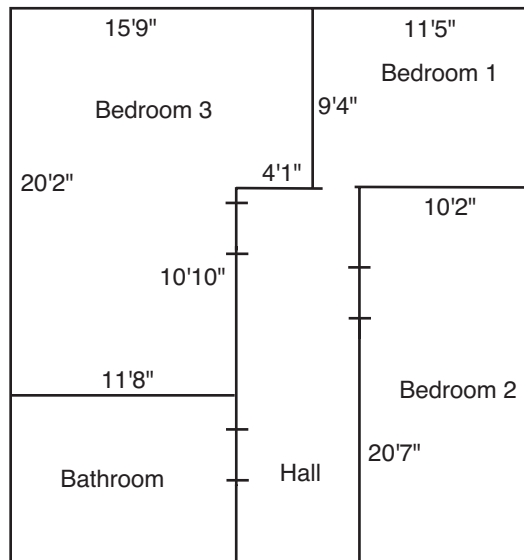

### 3. Sports Standings

2. Eastern Conference Standings for the NBA as of March 19, 2006

Atlantic Division				
Team	Wins	Losses	PCT	GB
New Jersey	36	28	.563	—
Philadelphia	31	34	.477	5.5
Boston	27	39	.409	10
Toronto	24	42	.364	13
New York	19	45	.297	17

Central Division				
Team	Wins	Losses	PCT	GB
Detroit	52	13	.800	—
Cleveland	37	29	.561	15.5
Indiana	33	30	.524	18
Milwaukee	33	33	.500	19.5
Chicago	29	37	.439	23.5

Southeast Division				
Team	Wins	Losses	PCT	GB
Miami	44	21	.677	—
Washington	33	31	.516	10.5
Orlando	24	41	.369	20
Atlanta	20	43	.317	23
Charlotte	18	49	.269	27

*(continued)*

### 3. Sports Standings

3.

Team	PCT	Reason for Invitation
1. Detroit	.800	First place in Central Division
2. Miami	.677	First place in Southeast Division
3. New Jersey	.563	First place in Atlantic Division
4. Cleveland	.561	Best percentage among non-leaders of division
5. Indiana	.524	Second best percentage among non-leaders of division
6. Washington	.516	Third best percentage among non-leaders of division
7. Milwaukee	.500	Fourth best percentage among non-leaders of division
8. Philadelphia	.477	Fifth best percentage among non-leaders of division

4. Chicago is in ninth place with a .439 winning percentage. They are 2.5 games behind Philadelphia.

### 3. Sports Standings

Newspapers print the standings of various sports leagues daily. The team in first place is usually listed at the top. “First place” status is based on best “winning percentage,” but “games behind” can also be used. Jose is a sports editor for the *Sunville Times*. He has to check the standings each day for accuracy (whether they are current or outdated).

Jose computes the winning percentage (PCT) by dividing the number of wins a team has by the number of games they have played. Jose then determines the games behind (GB) for each team. He subtracts a team’s wins from the first place team’s wins, then adds the team’s losses to this difference. The next step is to subtract the first place team’s losses. The resulting number is divided by 2.

Help Jose with his job by filling in the PCT and the GB fields in the charts below.

1. National League Final Standings 1962

Team	Wins	Losses	PCT	GB
St. Louis	93	69		
Cincinnati	92	70		
Philadelphia	92	70		
San Francisco	90	72		
Milwaukee	88	74		
Los Angeles	80	82		
Pittsburgh	80	82		
Chicago	76	86		
Houston	66	96		
New York	53	109		

2. Eastern Conference Standings for the NBA as of March 19, 2006

Atlantic Division				
Team	Wins	Losses	PCT	GB
New Jersey	36	28		
Philadelphia	31	34		
Boston	27	39		
Toronto	24	42		
New York	19	45		

(continued)

### 3. Sports Standings

Southeast Division				
Team	Wins	Losses	PCT	GB
Miami	44	21		
Washington	33	31		
Orlando	24	41		
Atlanta	20	43		
Charlotte	18	49		

Central Division				
Team	Wins	Losses	PCT	GB
Detroit	52	13		
Cleveland	37	29		
Indiana	33	30		
Milwaukee	33	33		
Chicago	29	37		

3. Now that you have calculated all the winning percentages and how far each team is behind in its division, determine who is in the lead to be a playoff team. Each division winner goes to the playoffs, and the five teams that are not division winners but have the best winning percentages are invited to the playoffs as well. Which eight teams would be invited to the playoffs based on these standings? Complete the chart on the next page.

*(continued)*

### 3. Sports Standings

Team	PCT	Reason for Invitation
1.		
2.		
3.		
4.		
5.		
6.		
7.		
8.		

4. Which team is sitting in ninth place, and how far from being in the playoffs are they?