

# Using Benchmarks

## Fractions and Operations



# TEACHER BOOK

# Mathematical Concepts Covered for Using Benchmarks: Fractions and Operations

**Book Description:** Students use the fractions  $\frac{1}{2}$ ,  $\frac{1}{4}$ ,  $\frac{3}{4}$ , and  $\frac{1}{10}$ ; the decimals 0.1, 0.5, 0.25, and 0.75; and the percents 50%, 25%, 75%, 100%, and the multiples of 10% as benchmarks to describe and compare all part-whole relationships.

Lesson Number:	Lesson Name:	Mathematical Concepts/Topics Covered
Opening the Unit	Using Benchmarks	<ul style="list-style-type: none"> <li>Fractions <math>\frac{1}{2}</math>, <math>\frac{1}{4}</math>, and <math>\frac{3}{4}</math></li> <li>Halves as two equal parts of a whole</li> <li>Amounts compared to one-half</li> </ul>
Lesson 1	More Than, Less Than, or Equal to One-Half	<ul style="list-style-type: none"> <li>The part/whole relationship</li> <li>Fractional amounts compared to <math>\frac{1}{2}</math></li> <li>Multiple representations for <math>\frac{1}{2}</math>—decimal and percent</li> <li>A 'whole' stated as a fraction</li> </ul>
Lesson 2	Half of a Half	<ul style="list-style-type: none"> <li>Strategies for determining <math>\frac{1}{4}</math></li> <li>Multiple representations for <math>\frac{1}{4}</math></li> <li>Determining <math>\frac{3}{4}</math> and one whole based on one-fourth</li> </ul>
Lesson 3	Three Out of Four	<ul style="list-style-type: none"> <li>Strategies for finding <math>\frac{3}{4}</math> based on <math>\frac{1}{4}</math></li> <li>Using multiple representations for <math>\frac{3}{4}</math></li> <li>Multiplying and dividing to find <math>\frac{3}{4}</math></li> </ul>
Lesson 4	Fraction Stations	<ul style="list-style-type: none"> <li>Fractions compared and described in relation to benchmarks for assessment purposes</li> </ul>
Lesson 5	A Look at One-Eighth	<ul style="list-style-type: none"> <li>Strategies for finding <math>\frac{1}{8}</math> of a given amount</li> <li>Less familiar fractions such as eighths and sixteenths related to halves and quarters</li> </ul>
Lesson 6	Equal Measures	<ul style="list-style-type: none"> <li>The meaning and value of any rational number written in fraction form <math>\frac{a}{b}</math>, where b is not zero</li> <li>Equivalent fractions</li> </ul>
Lesson 7	Visualizing and Estimating Sums and Differences	<ul style="list-style-type: none"> <li>Meanings of addition (combining) and subtraction (take away, difference, and missing part) to reason about fraction operations</li> <li>Tools (e.g., fraction strips, rulers, Pattern Blocks) to reason about combining fractions and finding differences.</li> </ul>

Lesson 8	Making Sensible Rules for Adding and Subtracting	<ul style="list-style-type: none"> <li>• Procedures for adding and subtracting fractions</li> <li>• Procedures for simplifying fractions</li> <li>• Procedures expressed in words and symbols</li> </ul>
Lesson 9	Methods for Multiplication with Fractions	<ul style="list-style-type: none"> <li>• Understanding of multiplication is demonstrated in various ways</li> <li>• Reliable methods for multiplication with fractions</li> <li>• Mathematical properties (such as the commutative, associative, distributive, inverse, and identity properties) with fractions and whole numbers</li> </ul>
Lesson 10	Fraction Division— Splitting, Sharing, and Finding How Many ___ in a ___?	<ul style="list-style-type: none"> <li>• Various ways to demonstrate understanding of division</li> <li>• Reasonable procedures for division of fractions</li> <li>• Application of properties (such as the commutative, associative, distributive) to operations with fractions</li> </ul>
Closing the Unit	Closing the Unit: Benchmarks Revisited	<ul style="list-style-type: none"> <li>• Part-whole situations described with fractions</li> <li>• A variety of ways such as pictures and number lines are used to model part-whole situations and operations</li> </ul>

# 6

## FACILITATING LESSON

# Equal Measures

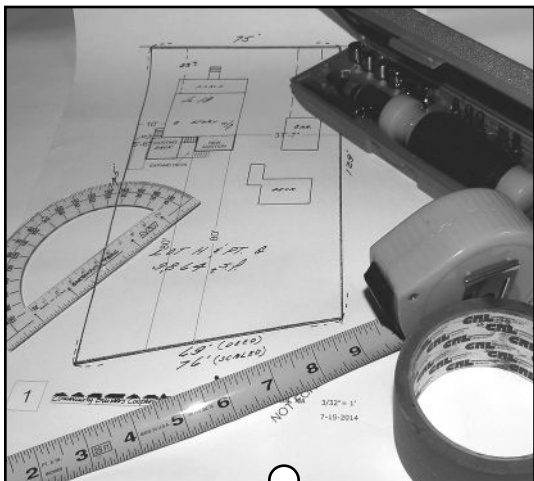

*What do fashion design, carpentry, cooking, and computer graphics have in common?*

## Synopsis

Students draw upon their prior knowledge of benchmark fractions to reason about fractional equivalents. They use a variety of tools to visualize fractions and equivalencies: fraction strips, inch-rulers, and Pattern Blocks. They reason and solve problems with the visual tools. Once their visual understanding is well grounded, students examine the formal mathematical approach to equivalent fractions, particularly the role the multiplicative identity (multiplication by 1) plays in generating equivalent fractions. They connect their visual models with the formal procedure.

1. Students review fraction equivalents with which they have become familiar (halves, quarters, and eighths), using a visual model.
2. Students create a set of fraction strips, add sixteenths to their repertoire and make connections to the lines on inch-rulers.
3. Students explore  $\frac{1}{2}$ ,  $\frac{1}{3}$ , and  $\frac{1}{6}$  equivalencies with Pattern Blocks and then fraction strips.
4. Students use the multiplicative identity to generate equivalent fractions and connect the formal math to their visual models.

## Objectives

- Interpret the meaning and value of numbers written in fraction form with any numerator or denominator (except for a denominator of zero)
- Generate and demonstrate equivalent fractions

## Materials/Prep

For *Activity 1*:

- Prepare paper strips (1" by 11"), in different colors. Make 5 unmarked strips per student.
- A plastic sheet protector containing one blank piece of paper, 1 per student
- Tape
- Colored markers (dry-erase), 1 per student
- 12-inch rulers marked to the nearest  $\frac{1}{16}$ " or *Blackline Master 3*

For *Activity 2*:

- Pattern Blocks. Use only yellow hexagons, blue parallelograms, red trapezoids, and green triangles or *Blackline Master 4*

For *Activity 3*:

- Prepare paper strips (1" by 11"), in colors different from those in *Activity 1*. Each student gets 3 unmarked strips, but make extras in case of error.

---

## Heads Up!

*Lessons 6 through 10* ground student reasoning in the informal and visual before presenting opportunities to use an algorithm or formal procedures to solve computation problems with fractions. Even if students remember procedures, ask them to put off using them in favor of solving problems visually so that everyone has the opportunity to make connections among the written problem, a visual representation of it, and strategies to solve it.

---

## Opening Discussion

Offer some examples to remind students that another way to write 1, as in one whole, is as a fraction with the same number in the numerator and denominator.



**Help me complete the story:**

**I had a total of \$20 in my wallet and I lost it all. Not half, but all, so \$20 out of \$20. I can write the whole amount as ... [ $\frac{20}{20}$ ].**

**My niece used up an entire 16 oz. bottle of shampoo. Not half, but all, so 16 oz. out of 16 oz. I can write the whole amount as ... [ $\frac{16}{16}$ ].**

**I recycled every one of my 30 plastic bags in the house. Not  $\frac{1}{2}$ , but all. So I can write that whole amount as ... [ $\frac{30}{30}$ ].**

Ask students to state the point in their own words. Offer your own summary along these lines:



**There's more than one way to write 1 when it means ALL, the "whole." Fractions are flexible. It is a useful characteristic because it gives us a way to operate with them and simplify answers. But it also means they can be tricky. This lesson focuses on equivalent fractions. Because of equivalence, we can name part-whole fractions of the same value in many ways.**

Write the following 17 fractions on the board in this random order:

$\frac{0}{8}$ ,  $\frac{1}{2}$ ,  $\frac{3}{4}$ ,  $\frac{3}{8}$ ,  $\frac{2}{2}$ ,  $\frac{7}{8}$ ,  $\frac{4}{4}$ ,  $\frac{2}{4}$ ,  $\frac{5}{8}$ ,  $\frac{0}{4}$ ,  $\frac{1}{4}$ ,  $\frac{6}{8}$ ,  $\frac{8}{8}$ ,  $\frac{0}{2}$ ,  $\frac{1}{8}$ ,  $\frac{2}{8}$ ,  $\frac{4}{8}$

Say:



**I just wrote 17 benchmark fractions you have been working with on the board.**

- a. Put them in order, from smallest to largest values.
- b. What do you notice about the fractions? Which (if any) are the same? How do you know?

Ask pairs to work together on creating a context and a visual to show how someone could “see” the relative values and get the point that some are equivalent. Emphasize the following as you give directions:



**Use all 17 fractions. Be creative! The visual model can be anything you want—pizzas, cakes or other food, money, a number line, a group of objects—so long as you are clear about what “One Whole” (1) represents.**

**Make clear sketches or diagrams that others will be able to understand.**

When pairs have completed their diagrams, ask them to exchange with another pair, answering the following questions:

- How clear is the other pair’s drawing to you? Do you have suggestions to make it clearer?
- What is the same about the other pair’s drawing and your drawing?
- What is different?
- Did you both come to the same conclusion?
- What is that conclusion?

Listen carefully to students’ understandings.

Make sure there is sound understanding of the correct order and equivalencies, and that there are 9 different values represented by the 17 fractions

$$\frac{0}{8} = \frac{0}{4} = \frac{0}{2}$$

$$\frac{1}{8}$$

$$\frac{2}{8} = \frac{1}{4}$$

$$\frac{3}{8}$$

$$\frac{4}{8} = \frac{2}{4} = \frac{1}{2}$$

$$\frac{5}{8}$$

$$\frac{6}{8} = \frac{3}{4}$$

$$\frac{7}{8}$$

$$\frac{8}{8} = \frac{4}{4} = \frac{2}{2}$$

Transition to *Activity 1*.



**Today we are going to focus attention on fractional equivalents—equal fractions. It’s important that you “see” the equivalence and that you then think about some mathematical rules for equivalent fractions.**



## Activity 1: Fraction Strips with Rulers—Tools to Think With

For each student, have 5 strips of different colored paper, each 1" by 11", tape, clear plastic sheet protector, and colored markers. They will keep this fraction kit for the rest of the lessons.

Pass out 5 different colored strips to each student. Hold up the first piece and say:



**Let's call this 1, or one whole. Mark it with a big "1."**

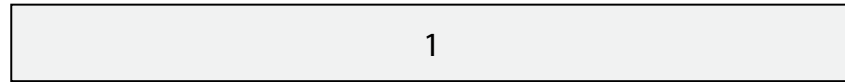

Hold up a second piece and say:



**I would like to fold this strip in half. How could I do this?**

Make sure students fold width to width, not length to length. Have them fold and open the strip up and then say:



**How do you know this is  $\frac{1}{2}$ ? What does  $\frac{1}{2}$  mean?**

Students should say there are 2 equal parts, so one part out of two is  $\frac{1}{2}$ . Direct them to label each piece as  $\frac{1}{2}$  and mark the crease line with markers.



Take another strip of a different color and say:



**I would like to fold this strip into fourths. How could I do this?**

Students should recall half of a half, or fold it 2 times. Open it up and say:



**How do you know this is  $\frac{1}{4}$ ? What does  $\frac{1}{4}$  mean?**

Students should recall 4 equal parts, one part of the four is  $\frac{1}{4}$ . Have them label every part with  $\frac{1}{4}$  and mark each crease line with markers.



Take a fourth strip and say:



**I wonder what would happen if I fold this in half strip 3 times? How many parts will there be?**

Listen for answers. Some students might say 6 thinking the segments are increasing by 2. Fold the strip in half 3 times (half of a half of a half) and open. There will be 8 sections. Ask:

 **What fractional parts are represented here? How do you know?**

Like before, have them label each part as  $\frac{1}{8}$  and mark each crease line.

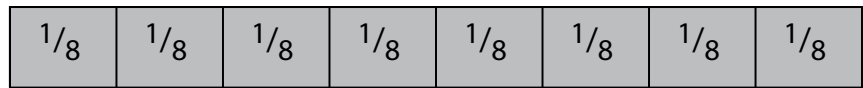

Pass out the last strip.

 **Do you see any patterns? How many times do you think we will fold this strip? How many equal parts do you think we'll find?**

Listen for answers. Most should say 16 parts. Fold the strip 4 times. Again, unfold and label each part as  $\frac{1}{16}$ .

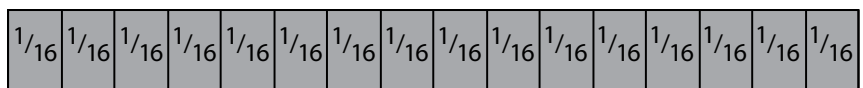

 **Do you think we could continue to do this? Fold it in half 5, 6, or 7 times?**

Most students will think it is impossible because of the thickness of the paper. If that didn't restrict us could we continue to do this? Yes. This is called density of fractions and there are an infinite number of fractions between 0 and 1.

Have students take the 5 strips and lay them one at a time in the sheet protector against a blank sheet of paper. Holding the protector with the hole punches facing up, lay sixteenths across the top edge, eighths underneath sixteenths, etc. Use tape only if a student needs it.

Using dry erase markers, tell students we are going to find fraction equivalencies and draw lines down the ends of ones that match. Start by drawing a line between the first two  $\frac{1}{16}$  pieces.

Say:

 **Look at  $\frac{1}{16}$ . Does it match (line up) with any other fractions? (No.)**

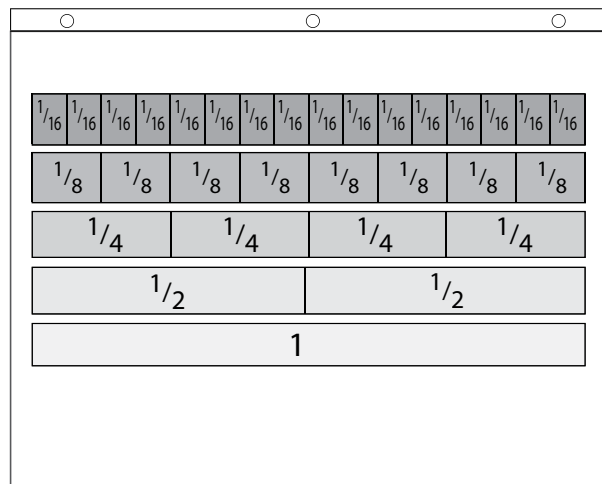



Look at  $\frac{2}{16}$ . Does it match up with any other fractions? (Yes,  $\frac{1}{8}$ .)

Draw a line down the edge of  $\frac{2}{16}$  to the edge of  $\frac{1}{8}$ . See example:

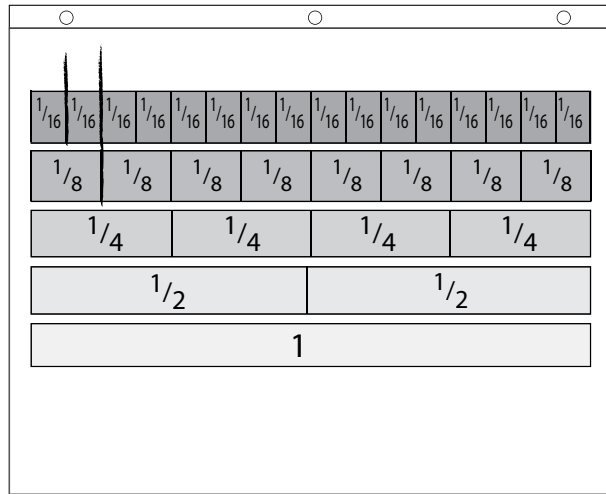

Does  $\frac{3}{16}$  line up with any other fractions? (No.)

Draw a line down the edge of  $\frac{3}{16}$  only (stop at the edge of the 16ths strip).

Does  $\frac{4}{16}$  line up with any other fractions?

This time it will match both  $\frac{2}{8}$  and  $\frac{1}{4}$ . Draw a line down the edge of  $\frac{4}{16}$ ,  $\frac{2}{8}$ , and  $\frac{1}{4}$ . See example:

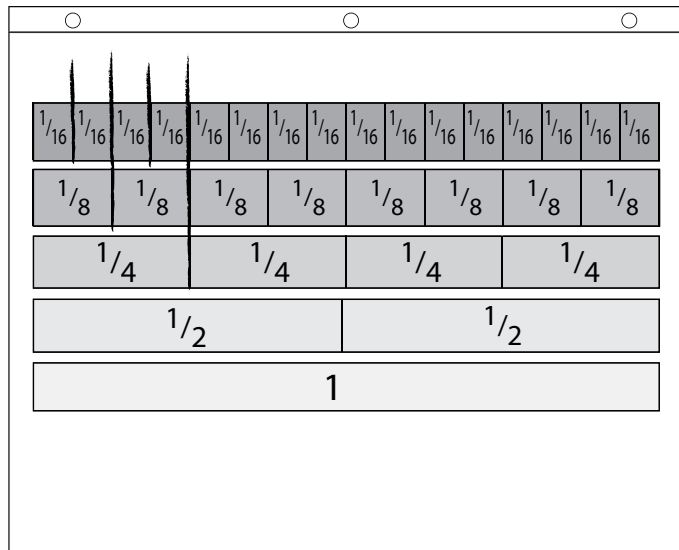

Continue with  $\frac{5}{16}$  (no matches),  $\frac{6}{16}$  (will line up with  $\frac{3}{8}$ ),  $\frac{7}{16}$  (no matches), and then  $\frac{8}{16}$  which will have the most matches. At this point it should look like this:

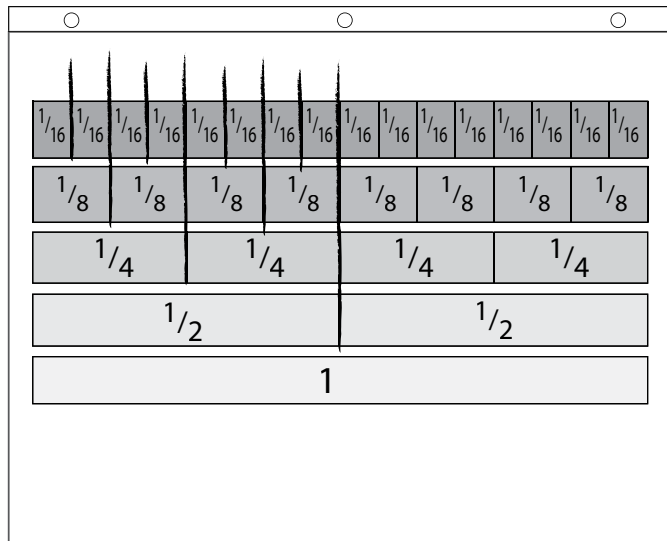

Continue this process all the way across the strip. When done, remove the fractions strips from the sheet protector and turn the sheet protector around so the lines go up instead of down.

 **What does this look like to you?**

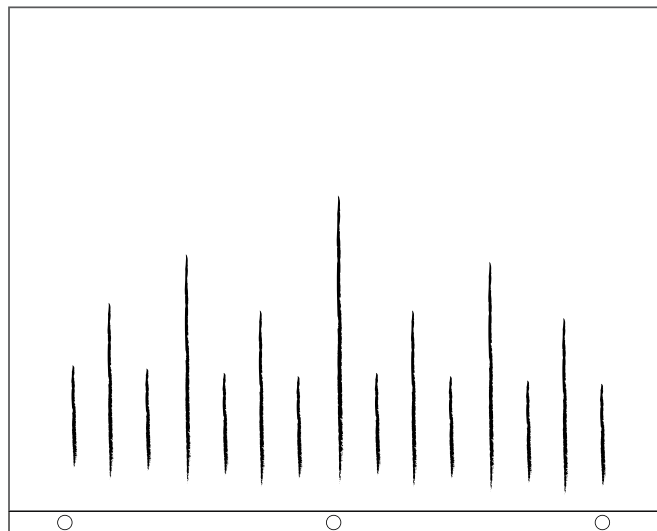

What remains are the markings of a ruler, where the 1 whole could be thought of as a “blown up” inch on the inch-ruler.

Ask individuals to work with a partner on *Activity 1: Fraction Strips and Rulers—Tools to Think With* (*Student Book*, p. 88).

 **Look at the fraction strips you created and the markings of the ruler to record as many equivalencies as you notice. Then create some of your own. Be prepared to justify your thinking with a picture.**

-  Write two sentences, each saying one thing you noticed as you were marking equivalent fractions.

## Activity 2: Pattern Blocks—Another Tool

Form pairs. Distribute some Pattern Blocks to each pair, asking students to take a few yellow, red, blue, and green shapes. If actual pattern blocks are not available, create sets for students using copies of *Blackline Master 4: Pattern Blocks* and colored markers or use an online tool such as <https://www.mathlearningcenter.org/apps/pattern-shapes>

Say:

-  In this activity, you are going to explore the fraction equivalents and values you “see” in these shapes.

Hold up the yellow hexagon and say:

-  For the purposes of this activity, the yellow hexagon is equal to 1 (one whole).

Direct students to *Activity 2 (Student Book, p. 89-91)* and ask them to work together to answer the questions.

If some pairs finish sooner than others, challenge them with the question:

-  What are all the values in *Activity 2* if, instead of the hexagon being the whole, the red trapezoid is the whole (equal to 1)?

## Activity 3: Thirds and Sixth Strips

Distribute more 1" by 11" strips. Students will add thirds, sixths, and one other strip to their kit of fraction strips. Ask them first to create the strip representing thirds. Guide students to make thirds by thinking about a folded letter . Demonstrate how to fold the ends toward each other without creasing until there is an equal amount of the strip overlapping. Then, have students crease the folded section. Say:

-  First, predict which benchmark fractions ( $\frac{1}{2}$ ,  $\frac{1}{4}$ ,  $\frac{3}{4}$ ) you think one-third is between, then see if your prediction is correct. Based on your strips, which of the two benchmark fractions is  $\frac{1}{3}$  closer to? Why do you think that is so?

Direct students to look at all their benchmark fraction strips, including eighths and sixteenths and compare them to  $\frac{1}{3}$ . Ask:

-  One-third is between which two fractions?

Have students mark their strips along the crease line and label each section  $\frac{1}{3}$ .

Choose another color strip and ask students how they would create sixths.

-  Now, predict which set of benchmark fractions  $\frac{1}{6}$  falls between. Test out your prediction. What reasoning did you use to make your prediction?

Have students mark their strips in sixths. Ask students to think back to how they created their earlier strips, beginning with halves, then fourths. Hold up the remaining strip.

 **Predict the size of the fraction you would get when you divide sixths in half. Create and label the new strip (in twelfths).**

Students mark their strip in twelfths. If some students finish sooner than others, challenge them with the following:

 **Name and show two equivalent fractions between  $\frac{1}{3}$  and  $\frac{1}{2}$ .**

Add one-third to the class vocabulary list while students add one-third to their lists (*Student Book*, p. 166). Listen to make sure that students capture the idea of forming thirds by dividing by 3.

Direct students to Activity 3 (*Student Book*, p.92) and ask them to work together to answer the questions.

## **Activity 4: About Ones and Zeroes**

Ask pairs to think about the following four statements (that you have posted).

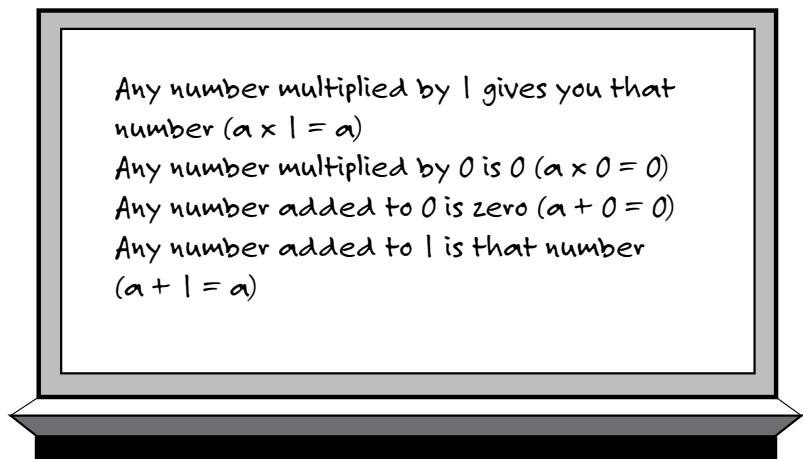

 **Are these statements true or false?**

After pairs have made decisions, ask for a vote, and facilitate a discussion. Finally, direct students' attention to *Activity 4: About Ones and Zeros* (*Student Book*, p. 93). The first section will be a place to record their notes of the discussion of the four statements. In the second section, they are asked to put those ideas into use.

Ask students to say what they are noticing in their own words. Write their words on the board verbatim. The take-home points from this investigation might be:

- 1 can be written in many ways. In fact, any number can be written in many ways.
- No matter the form, when one multiplies a number by 1, the product is that number. (Focus on this as the important idea that underlies the math of equivalent fractions.)

- If you start with a fraction, you can always get a fraction equal to it by multiplying by 1.
- $\frac{2}{2}$ ,  $\frac{3}{3}$ ,  $\frac{4}{4}$  ... , etc., are forms of 1 that are useful for generating equivalent fractions.



## Math Inspection: One in the Denominator

This inspection is meant to help students understand the meaning of a fraction with a 1 in the denominator, distinguishing between the meaning of 1 in the denominator and 1 in the numerator.

Students often have a hard time understanding fractions greater than one. You might encourage students to focus on the size of the piece that makes the whole. For example, if the size of the piece is 1 and you have 5 of these then you have  $\frac{5}{1}$ . You can also build on students' understanding that if they have a whole that is divided into quarters, they have  $\frac{4}{4}$ , noting that the 4 in the denominator refers to the number of slices in a whole. An equivalent fraction can be written  $\frac{1}{1}$ , whereas five times this amount can be written  $\frac{20}{4}$  or  $\frac{5}{1}$ . This might help students feel more comfortable interpreting fractions with 1 in the denominator.

Ask students to explain each of their answers (True or False), not just the False ones. Problem 3 is one that often confuses students, and one that will allow you to assess their understanding of the meaning of a fraction. Listen for explanations of how  $\frac{1}{5}$  and  $\frac{5}{1}$  are different. Problem 7 is a generalization about the equivalence between a fraction with a denominator of 1 and the number in the numerator of that fraction. You may want to ask them to restate this idea using their own words.

## Summary Discussion

Ask each person to write down two or three statements about equivalent fractions. Then ask them to pass those statements to a partner to discuss each statement's accuracy. Finally, ask each pair to offer one statement they feel confident about, and any that they might be uncertain about. You might hear ideas like these:



- Any fraction can be turned into an equivalent fraction by splitting each piece that makes up the whole (the denominator) into two equal parts.
- The denominator for the new fraction will be twice the original fraction because there are twice as many pieces in the whole.
- The numerator for the new fraction will be twice the original numerator. To make it an equivalent fraction, we need to keep the value the same, and to keep the balance, there have to be twice as many pieces in the numerator as well as the denominator. For example, in  $\frac{3}{4} = \frac{6}{8}$ , each of 4 pieces in the whole was split into two, so there are 8 pieces in the denominator. And each of 3 pieces in the numerator was also split into two, so there are 6.
- There are more pieces, but they are smaller.

If the above points are not mentioned, add them to the list.

Tell students to turn to *Reflections* (*Student Book*, p, 171), to record their thoughts about equivalent fractions.



## Practice

*Equivalent Fractions*, p. 96

For more practice on finding equivalent fractions.

*Between 1/3 and 1/2*, p. 97

For practice using the benchmark fractions  $\frac{1}{3}$  and  $\frac{1}{2}$ .

*Ratcheting Up (or Down) a Notch*, p. 98

For practice with sixteenths and thirty-secondths.

*Where to Place It?*, p. 99

For practice placing fractions on a number line.

*2/3 and 3/4*, p. 100

For practice placing fractions on a number line.



## Mental Math Practice

*Using Properties*, p. 101



## Test Practice

*Test Practice*, p. 102



## Looking Closely

Observe whether students are able to

### **Describe the meaning and value of numbers written in fraction form**

The language and sketches students have used to represent halves and fourths should be familiar and generalizable at this point, easily applied to any number in the form  $a/b$ , (numerator over the denominator). Still, students might be confused by fractions with similar numbers, like  $\frac{3}{5}$  and  $\frac{5}{3}$ . Look for evidence that students can use visual tools to reason about fractions. Offer fraction strips, tiles, rulers, and Pattern Blocks to assist them in making sense of fractions of any number.

### **Generate and demonstrate equivalent fractions**

Before using equivalent fractions in operations, students should take time to compare fraction strips, to see how the same part-whole relationship can be labeled with a variety of fractions. It is essential that if students question or are confused by equality and equivalence, you affirm that the numbers are different, but the part-whole relationship is equivalent. Half of \$40 is a larger number of money than half of \$10. But the relationship is equivalent. It's half in either case.

## LESSON 6 COMMENTARY

---

### Rationale

*Lessons 1–5* scaffold students’ reasoning about part-whole relationships. By sketching and manipulating objects, students should have a grasp on halves and quarters and their equivalents before they begin doing formal mathematical procedures like simplifying fractions. Even if students remember procedures, asking them to solve problems visually first, then connecting their reasoning and steps to the math procedures, helps keep the meaning intact. We are guided by the writing of well-respected mathematics teacher educators, and believe their insights hold true for adults as well as younger learners:

... It makes sense to delay computation and work on concepts if students are not conceptually ready.

Premature attention to rules for fraction computation has a number of serious drawbacks. None of the algorithms helps students think about the operations and what they mean. When students follow a procedure they do not understand, they have no means of assessing their results to see if they make sense. Second, mastery of the poorly understood algorithm in the short term is quickly lost. When mixed together the differing procedures for each operation soon become a meaningless jumble.

— Van de Walle, J., K. Karp, J. Bay-Williams, 2012

### Math Background

So much about operations with fractions hinges on understanding equivalent fractions and how one comes by them. Equivalent fractions have the same value. The idea that a quantity can have more than one name is essential. Students can do this; they know calling someone by a first name, combination first name and last name, or last name with a title, like Ms. Cisneros, can communicate different messages, but it is still the same person. The relationship of half is still the same, whether we have 8 out of 16 or 50 out of 100. Calling on different names as well as finding and using equivalent relationships, like  $\frac{2}{4}$  instead of  $\frac{1}{2}$ , makes it possible to combine and compare fractions.

It is easy to lose focus on the whole, but having that as a focus should enable students to use the identity ‘principle’ (property),  $x/x=1$ . If you start with a fraction, you can always find an equivalent fraction by multiplying by one.

In the next lessons students will look for “whole” or “one” within an improper fraction. They will find equivalent fractions to make combining and subtraction easier.

### Context

Mention tools like ratchets, measuring cups, or other objects that come in a sequence of sizes labeled with fractions. Particularly listen for those with which students might be familiar.

## Facilitation

Some students might choose to label below the line instead of labeling on the number strip.

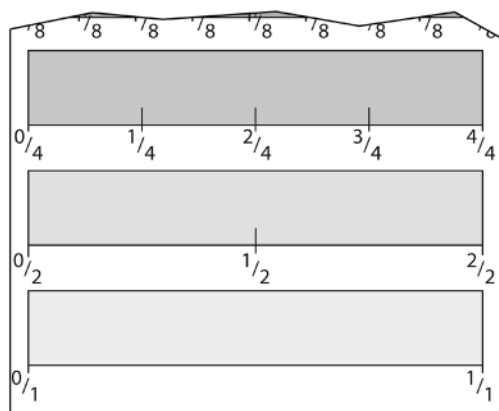

### Making the Lesson Easier

Keep fraction strips, Pattern Blocks, and number lines handy. Skip the 17 fractions during the *Opening Discussion*, but bring them up in the *Summary Discussion*. Skip sixths and come back to them later as a way to introduce fractions equivalent to one-third and two-thirds.

### Making the Lesson Harder

For *Activity 3*, ask students to recall the mental math strategies they used to find the decimal and percent equivalents for benchmark fractions like one-half, a one-quarter, and one-eighth. Students should recall that a quarter is 25% and half of a quarter is one-eighth. By that token, half of 25% is 12.5%. While most of us might not be able to divide by 8 or multiply by .125 using mental math, many of us can in our heads, divide in half, half, and half again. So finding 12.5% of any number suddenly becomes very doable.

If students seem to grasp this idea easily, you may encourage them to explore the relationships among thirds and sixths and their decimal equivalents. You might need to remind them that if they don't know an equivalent off the top of their heads, one way to do this is to divide with a calculator the denominator into the numerator. Discuss relative size and the fact that in most situations with thirds, you round off with .33 or .66 because the decimal does not resolve. Following the pattern of half of one-quarter (25%) is 12.5%, see if they can find the percent equivalent for  $\frac{1}{6}$ , which is approximately .17. These ideas can be revisited when students study thousandths in *Split It Up*.



During the opening discussion to put fractions in sequential order, I saw many groups of students use shapes such as circles and rectangles. Another group used one big number line, stacking equivalent fractions on top of each other to show they coincided on the number line. The groups using shapes did a lot of erasing and re-drawing when they discovered a new fraction that was in between the others. The group with the number line finished faster than the other groups. When the groups compared their results and methods, the groups with shapes all agreed that the number line method seemed easier to follow and understand than the various pictures of shapes.

*Activity 1* is one I look forward to, but I notice many students are bored with it at first. The folding seems predictable and easy to them since we've done so much work with halves, fourths and eighths up to that point. However once we have taped the strips together and start finding equivalencies, the students light up. Most students appreciated having a visual way of finding equivalencies and planned to keep their plastic sleeve of fraction strips even as they continued on to new math classes.

A big eye opener for me was *Activity 3*, having the students predict where they thought one-third would fall on their fraction strips. Instead of using what they knew about part and whole to make the prediction, they seemed to be guessing. I am surprised by how many students say one-third will be smaller than one-fourth. Then we used the strips to fold thirds and compared to other fractions and students recalled that as the size of the pieces increases, the denominator gets smaller.

*Jill Gorneau  
Portland Adult Education, Maine*

# Using Benchmarks

## Fractions and Operations



# STUDENT BOOK

# LESSON 6

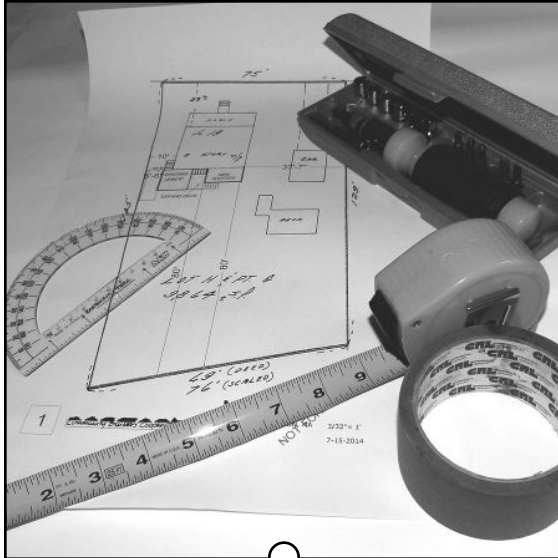

## Equal Measures

*What do fashion design, carpentry, cooking, and computer graphics have in common?*

***Every number can be written in many forms.*** How many ways do you know to write a number that means the same as two and a half? How are you sure that a number is equal to three-fourths? When numbers look different but have the same value, they are equivalent (like 1 and 100%). Sometimes numbers look almost alike, but do not have the same value (like \$250 and \$2.50). They are not equivalent.

People working in professions where measurement is important know this well. Errors can be expensive! Carpenters have a saying: Measure twice, cut once.

In this lesson, you will need to keep your eyes sharp and pay close attention. Consider the value of the quantities. Give yourself time to think about the meaning of the numbers.



## Activity 1: Fraction Strips and Rulers—Tools to Think With

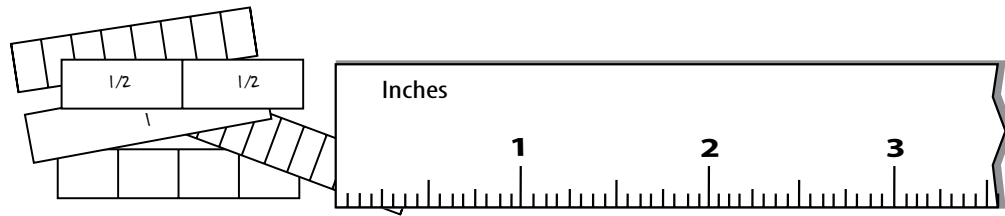

1. Think with the fraction strips and the inch ruler!
  - a. Look at a set of fraction strips and the markings on a ruler. Write all of the fraction equivalencies you see.  
  
Example:  $\frac{8}{16} = \frac{1}{2}$
2. With a partner, list examples for each fraction below.
  - a. Five fractions that are equivalent to  $\frac{3}{4}$ . Show your thinking for one example with a picture.
  - b. Five fractions that are equivalent to  $1\frac{1}{2}$ .
  - c. Four fractions that are equivalent to  $\frac{14}{16}$ .
  - d. Describe the strategy or strategies you used to create an equivalent fraction.



## Activity 2: Pattern Blocks—Another Tool

You will need a pile of Pattern Blocks for this activity.

- Counting the yellow hexagon as one, the whole, find the *fractional* value of
  - the green triangle \_\_\_\_\_
  - the red trapezoid \_\_\_\_\_
  - the blue parallelogram \_\_\_\_\_
- Examine the Pattern Blocks to answer each of the following questions. Show the equivalence with a picture, a math equation, and words.

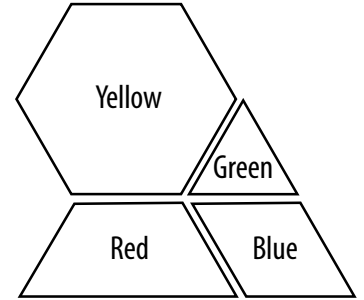

- How many green triangles equal 1 yellow hexagon?

The picture

The math equation

The math in words

- How many blue parallelograms equal 1 yellow hexagon?

The picture

The math equation

The math in words

c. How many red trapezoids equal 1 yellow hexagon?

The picture

<b>The math equation</b>
<b>The math in words</b>

d. How many green triangles equal 1 red trapezoid?

The picture

<b>The math equation</b>
<b>The math in words</b>

e. How many green triangles equal  $2\frac{1}{2}$  yellow hexagons?

The picture

<b>The math equation</b>
<b>The math in words</b>

f. How many blue parallelograms equal 1 red trapezoid?

The picture

The math equation
The math in words

g. How many blue parallelograms equal 2 red trapezoids?

The picture

The math equation
The math in words

3. Show two more equivalent statements.



### Activity 3: Fraction Strips with Thirds and Sixths

1. Line up the following unit fractions in order from smallest to largest. Then describe the pattern you see.

$$\frac{1}{12} \quad \frac{1}{2} \quad \frac{1}{4} \quad \frac{1}{8} \quad \frac{1}{16} \quad \frac{1}{6} \quad \frac{1}{3}$$

2. Now look at the fraction strips you created, including the three new ones. With your partner write all the fraction equivalencies you see. Be prepared to show your thinking.

Example:  $\frac{2}{4} = \frac{1}{2}$

3. When you divided  $\frac{1}{2}$  into two equal smaller parts, you got a set of fourths. When you divided each of the fourths into two smaller parts, you got eighths.

- a. Describe the rule for breaking a fraction into two equal parts.

- b. Create some new fractions based on your rule.

Example:  $\frac{1}{16} = \frac{2}{32}$

4. Use your strips to explain why  $\frac{1}{3}$  is closer to  $\frac{1}{4}$  than  $\frac{1}{2}$ .





## Activity 4: About Ones and Zeroes

1. True or false? Explain your reasoning with examples. Rewrite any false statements to make them true.

a. Any number multiplied by 1 gives you that number. In other words,  $a \times 1 = a$ . True or false?

Examples:

b. Any number multiplied by 0 is 0. In other words,  $a \times 0 = 0$ . True or false?

Examples:

c. Any number added to 0 is zero. In other words,  $a + 0 = 0$ . True or false?

Examples:

d. Any number added to 1 is that number. In other words,  $a + 1 = a$ . True or false?

Examples:

2. Use the true statements about 0 and 1 to do the calculations efficiently.

a.  $\frac{3}{4} \cdot 0 =$

e.  $\frac{3}{4} (4 - 3) =$

b.  $\frac{5}{16} \cdot 0 =$

f.  $\frac{1}{2} (100 - 99) =$

c.  $\frac{5}{16} + 0 =$

g.  $\frac{1}{2} (\frac{1}{2} + \frac{1}{2}) =$

d.  $\frac{5}{16} + 1 =$

h.  $\frac{5}{16} (2\frac{1}{4} - 1\frac{1}{4}) =$

3. Create some of your own examples using the rules about 0 and 1.

4. You already know that  $\frac{2}{2} = 1$ , that  $\frac{4}{4} = 1$ , and that  $\frac{8}{8} = 1$ . Use that understanding to do the calculations below more efficiently.

a.  $\frac{1}{2} \times \frac{2}{2} =$

b.  $\frac{1}{2} \times \frac{4}{4} =$

c.  $\frac{1}{2} \times \frac{8}{8} =$

d.  $\frac{1}{2} \times \frac{16}{16} =$

Do you agree or disagree with this statement about equation 4a.?

*“There are at least two correct answers:  $\frac{1}{2} \times \frac{2}{2} = \frac{1}{2}$  and  $\frac{1}{2} \times \frac{2}{2} = \frac{2}{4}$ .”*

Explain your reasoning.

5. What strategies can you use for creating equivalent fractions?

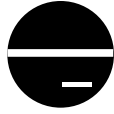

## Math Inspection: One in the Denominator

We've looked at many fractions and equivalent fractions. Many have had 1 in the numerator, but what about a 1 in the denominator?

Mark the statements True or False. Rewrite any false statements to make them true.

1. A fraction with a 1 in the denominator is equivalent to 1. True or false? \_\_\_\_\_

2. If a fraction has a 1 in the denominator, it is equal to  $\frac{1}{2}$ . True or false? \_\_\_\_\_

3.  $\frac{1}{5} = \frac{5}{1}$ . True or false? \_\_\_\_\_

4.  $\frac{12}{1} = 12$ . True or false? \_\_\_\_\_

5.  $\frac{24}{1} = 2$ . True or false? \_\_\_\_\_

6.  $\frac{4}{1} = 4$ . True or false? \_\_\_\_\_

7. A fraction with a denominator of 1 is equivalent to the number in the numerator. True or false? \_\_\_\_\_

8. Give a few examples of your own of fractions with a 1 in the denominator and an equivalent number.

a. \_\_\_\_\_ = \_\_\_\_\_

b. \_\_\_\_\_ = \_\_\_\_\_

c. \_\_\_\_\_ = \_\_\_\_\_



## Practice: Equivalent Fractions

1															
$\frac{1}{2}$								$\frac{1}{2}$							
$\frac{1}{4}$				$\frac{1}{4}$				$\frac{1}{4}$				$\frac{1}{4}$			
$\frac{1}{8}$		$\frac{1}{8}$		$\frac{1}{8}$		$\frac{1}{8}$		$\frac{1}{8}$		$\frac{1}{8}$		$\frac{1}{8}$		$\frac{1}{8}$	
$\frac{1}{16}$	$\frac{1}{16}$	$\frac{1}{16}$	$\frac{1}{16}$	$\frac{1}{16}$	$\frac{1}{16}$	$\frac{1}{16}$	$\frac{1}{16}$	$\frac{1}{16}$	$\frac{1}{16}$	$\frac{1}{16}$	$\frac{1}{16}$	$\frac{1}{16}$	$\frac{1}{16}$	$\frac{1}{16}$	$\frac{1}{16}$

Using the chart above or a set of fraction strips, fill in the numerators to make equivalent fractions.

$$1 = \frac{1}{2} = \frac{1}{4} = \frac{1}{8} = \frac{1}{16} \quad \text{then} \quad 1 = \frac{1}{3} = \frac{1}{5} = \frac{1}{6} = \frac{1}{7} = \frac{1}{9} = \frac{1}{15} = \frac{1}{18} \dots$$

Complete the following equivalent fractions using the chart above.

a.  $\frac{1}{2} = \frac{\quad}{4}$

h.  $\frac{1}{2} = \frac{\quad}{8}$

o.  $\frac{4}{16} = \frac{\quad}{4}$

b.  $\frac{1}{4} = \frac{\quad}{8}$

i.  $\frac{4}{4} = \frac{\quad}{8}$

p.  $\frac{4}{16} = \frac{\quad}{8}$

c.  $\frac{1}{8} = \frac{\quad}{16}$

j.  $\frac{3}{4} = \frac{\quad}{8}$

q.  $\frac{6}{16} = \frac{\quad}{8}$

d.  $\frac{1}{4} = \frac{\quad}{16}$

k.  $\frac{3}{4} = \frac{\quad}{16}$

r.  $\frac{8}{16} = \frac{\quad}{4}$

e.  $\frac{1}{2} = \frac{\quad}{16}$

l.  $\frac{3}{8} = \frac{\quad}{16}$

s.  $\frac{8}{16} = \frac{\quad}{2}$

f.  $\frac{2}{4} = \frac{\quad}{16}$

m.  $\frac{4}{8} = \frac{\quad}{16}$

t.  $1 = \frac{\quad}{16}$

g.  $1 = \frac{\quad}{4}$

n.  $1 = \frac{\quad}{8}$

u.  $1 = \frac{\quad}{2}$



## Practice: Between $\frac{1}{3}$ and $\frac{1}{2}$

Are the fractions below between  $\frac{1}{3}$  and  $\frac{1}{2}$ ? Show with pictures or words.

1.  $\frac{11}{20}$

2.  $\frac{9}{16}$

3.  $\frac{5}{12}$

4.  $\frac{6}{16}$

5.  $\frac{7}{14}$

6.  $\frac{9}{20}$

7.  $\frac{12}{15}$

8.  $\frac{2}{15}$

9.  $\frac{4}{9}$



## Practice: Ratcheting Up (or Down) a Notch

A ratchet fits a range of sockets from  $\frac{1}{32}$ " to  $\frac{31}{32}$ ". Each socket is  $\frac{1}{32}$ " larger than the one before. Use this information to answer the questions below.



1. Sam and Ashwin are trying to tighten the bolts on their picnic table. Sam grabs a ratchet with a  $\frac{5}{16}$ " socket. He realizes that is not quite big enough. Which size socket should he try next? Why?
2. Iolana is trying to tighten a bolt on a metal frame. She grabs a  $\frac{17}{32}$ " socket which is just a little bit too large. Which size should she try next? Why?
3. Jerry is trying to loosen a bolt on his tractor. He tries to use a  $\frac{5}{8}$ " socket, which is too small. Which size should he try next? Why?
4. Danni is trying to tighten a bolt on her treadmill. She tries to use a  $\frac{7}{16}$ " socket, which is too big. Which size should she try next? Why?
5. Samet is trying to loosen a bolt on his grill. He tries a  $\frac{7}{8}$ " socket, which is too small. Which size should he try next? Why?



## Practice: Where to Place It?

For each problem, mark the first given fraction on the line. Then circle the correct answer for whether the fraction is less than ( $<$ ), equal to ( $=$ ), or greater than ( $>$ ) the fraction it is being compared to.

1.  $\frac{17}{21}$  is less than ( $<$ )      equal to ( $=$ )      or greater than ( $>$ )  $\frac{2}{3}$ .

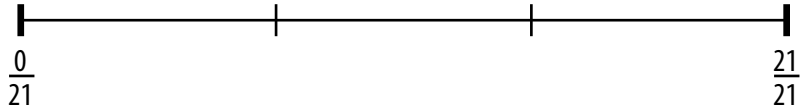

2.  $\frac{11}{15}$  is less than ( $<$ )      equal to ( $=$ )      or greater than ( $>$ )  $\frac{2}{3}$ .

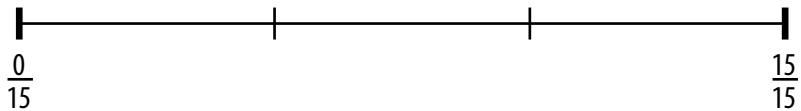

3.  $\frac{16}{45}$  is less than ( $<$ )      equal to ( $=$ )      or greater than ( $>$ )  $\frac{1}{3}$ .

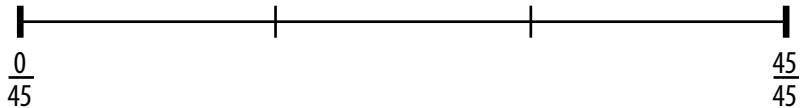

4.  $\frac{35}{60}$  is less than ( $<$ )      equal to ( $=$ )      or greater than ( $>$ )  $\frac{2}{3}$ .

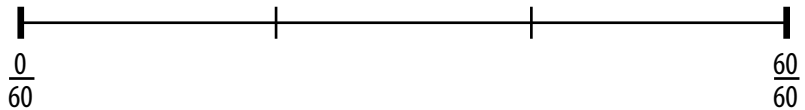

5.  $\frac{13}{30}$  is less than ( $<$ )      equal to ( $=$ )      or greater than ( $>$ )  $\frac{1}{3}$ .

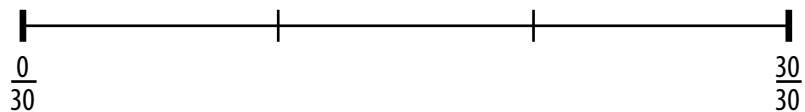



Practice:  $\frac{2}{3}$  and  $\frac{3}{4}$

1. Which is larger,  $\frac{2}{3}$  or  $\frac{3}{4}$ ? Show or explain how you know.

2. Name the points on the number line.

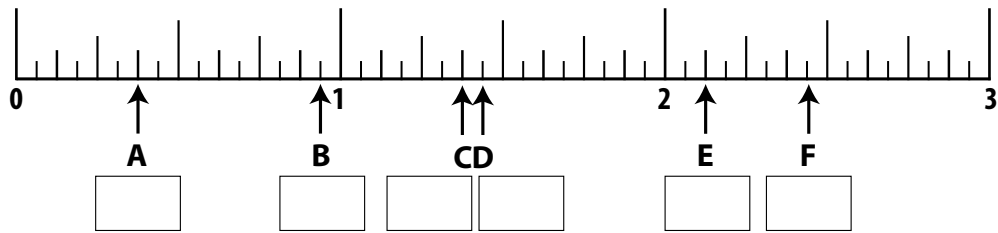

3. Show each point on the number line.

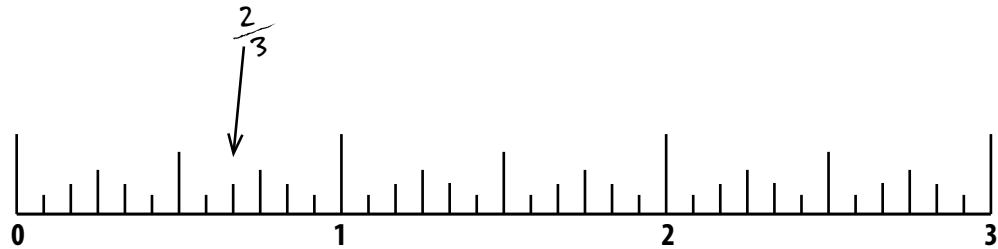

a.  $2\frac{1}{3}$

b.  $1\frac{5}{12}$

c.  $2\frac{5}{6}$

d.  $2\frac{1}{6}$

e.  $\frac{7}{12}$





## Mental Math Practice: Using Properties

Solve each of the problems below mentally.

1.  $\frac{3}{4} (\frac{2}{2} - \frac{4}{4})$

2.  $12 (\frac{1}{2} + \frac{1}{2})$

3.  $4 (\frac{1}{2}) + 6 (\frac{1}{2} - \frac{1}{2})$

4.  $8 (\frac{6}{8} - \frac{5}{8})$

5.  $-4 + 3 (\frac{1}{2} + \frac{1}{2})$

6.  $9 + (-3)(\frac{2}{4} - \frac{2}{4})$

7.  $50 (\frac{3}{4} - \frac{3}{4})$

8.  $-10 + 5(\frac{1}{2})(2)$

9.  $40 + (12)(\frac{1}{4})(4)$

10.  $-2 + 7(\frac{1}{2})(4)$

11.  $\underline{\hspace{1cm}} + 8 \frac{1}{4} = 12 - 2$

12. three-quarters of a million +  $\underline{\hspace{1cm}}$  = 1.5 million



## Test Practice

1. Saeed works 12-hour days, four days a week. Because they are long days, he thinks about how much work he has already finished in a day. So far today, he has worked 7 hours. What fraction of the day has Saeed worked?
- (a)  $\frac{4}{7}$   
(b)  $\frac{5}{12}$   
(c)  $\frac{7}{16}$   
(d)  $\frac{7}{12}$   
(e)  $\frac{1}{4}$
2. Sherry timed herself as she walked around the track. It took 20 minutes. What part of an hour does this represent?
- (a)  $\frac{20}{1}$   
(b)  $\frac{20}{40}$   
(c)  $\frac{1}{3}$   
(d)  $\frac{2}{3}$   
(e)  $\frac{1}{20}$
3. Zev is trying to save \$3,000 for a used car. So far he has saved about \$1,400. About what fraction of the total has he saved?
- (a) almost  $\frac{1}{4}$   
(b) almost  $\frac{1}{3}$   
(c) almost  $\frac{1}{2}$   
(d) almost  $\frac{3}{4}$   
(e) almost  $\frac{2}{3}$
4. Which of the following is not equivalent to  $\frac{2}{3}$ ?
- (a)  $\frac{4}{6}$   
(b)  $\frac{6}{9}$   
(c)  $\frac{8}{12}$   
(d)  $\frac{9}{12}$   
(e)  $\frac{10}{15}$
5. During a recent hurricane, about one-third of the population was without power. If the population is about 150,000, about how many people were without power?
- (a) 10,000  
(b) 50,000  
(c) 75,000  
(d) 100,000  
(e) 450,000
6. A small store tracked the payment type chosen by its customers during one day. According to the chart, about what fraction of purchases were made with credit cards?

ATM Debit	Credit	Cash
###	### ##	###
###	### ##	###
###	### ##	###
///	### ## ##	
	### ## ##	
	### /	